

## Technical Note

### Nikon Ti2 Laser Safety Stage Cover Installation Instructions

This document describes how to install this risk mitigation device to reduce access to laser radiation

1. Position the mounting bracket as shown and secure in position with the 2 off screws provided

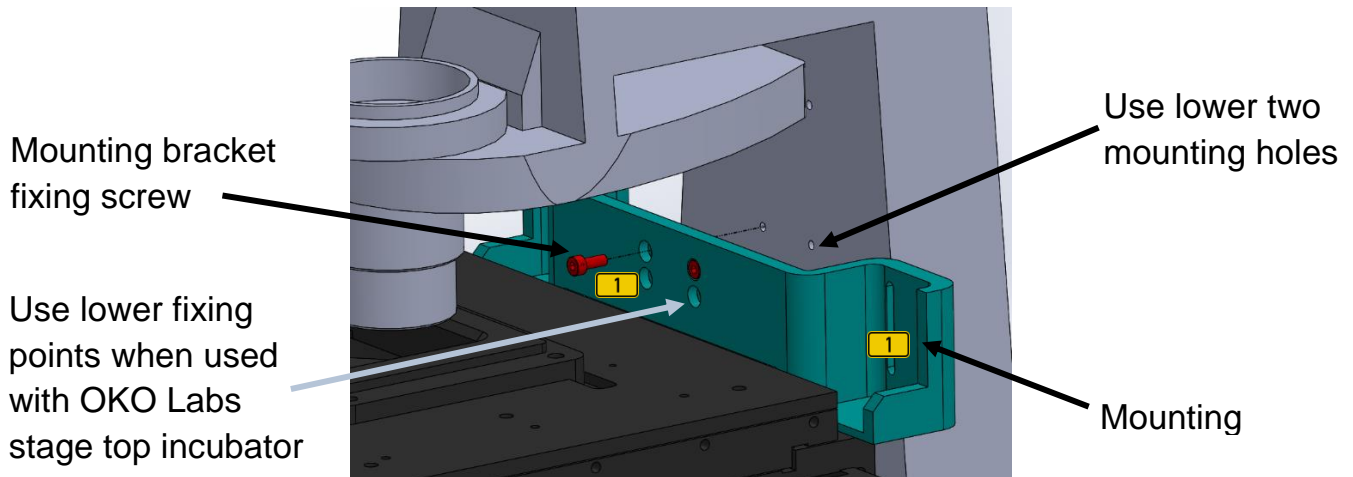

Figure 1: Mounting Bracket

2. Align the stage cover's mounting holes with the slots in the mounting bracket. Fit but do not fully tighten the 4 screws and washers provided. Carefully lower the stage cover assembly until it is approximately 2mm above the stage assembly and then tighten the screws

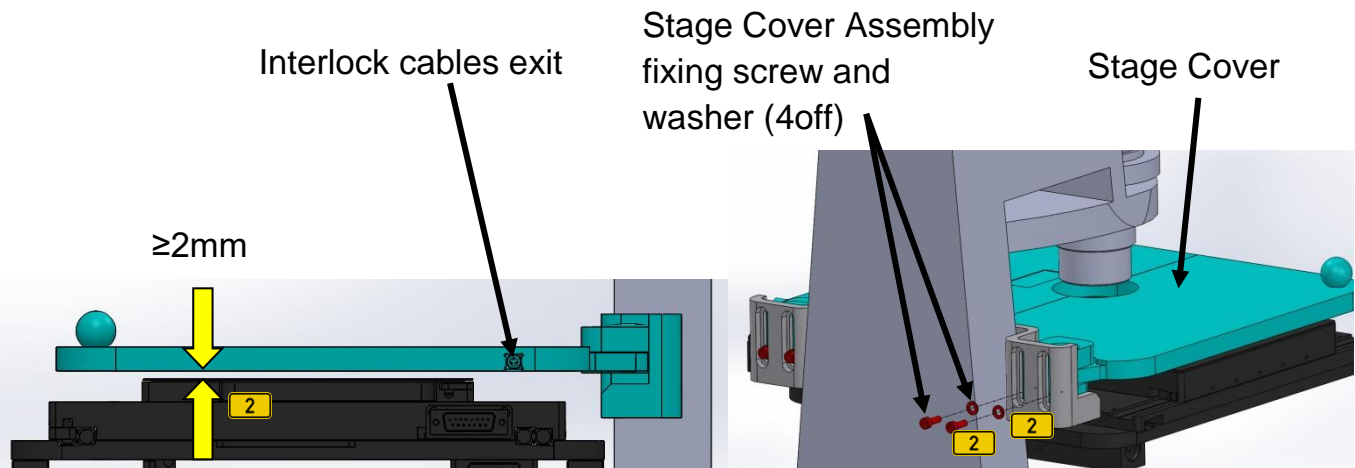

Figure 2: Securing the Stage Cover Assembly

3. Check that the condenser can be focused and still remain clear of the stage cover
4. Ensure that the stage cover can open freely
5. Get the External Interlock Cable (ASE-11399) out its bag, which was taped to the bottom of the stage cover
6. Connect the External Interlock Cable (ASE-11399) into the stage cover as shown overleaf

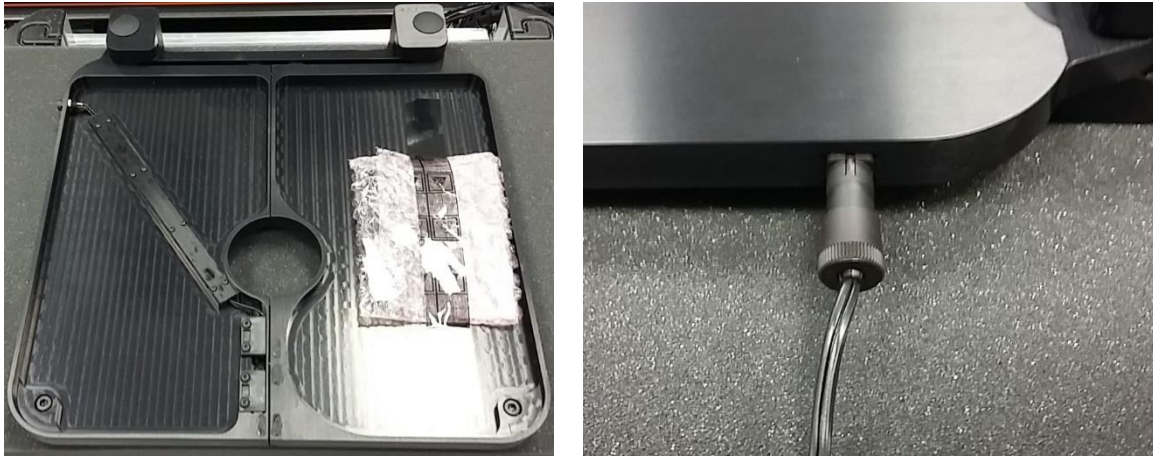

Figure 3: External Interlock Cable (ASE-11399) in Bag Underneath Stage Cover and Connected

7. Locate the section of interlock cable loom connected to your microscope, for example:

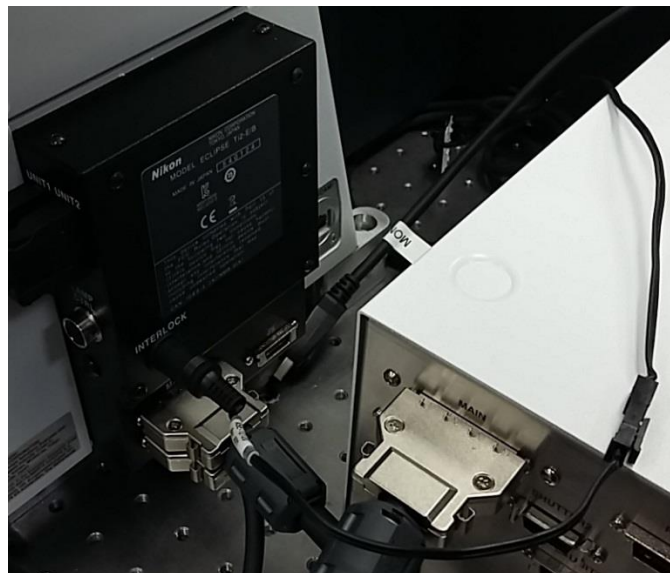

Figure 4: Nikon Ti2-E Interlock Connection

8. Disconnect the nearest Micro-Fit connection and connect the External Interlock Cable (ASE-11399) into this opening in the interlock cable loom as shown below:

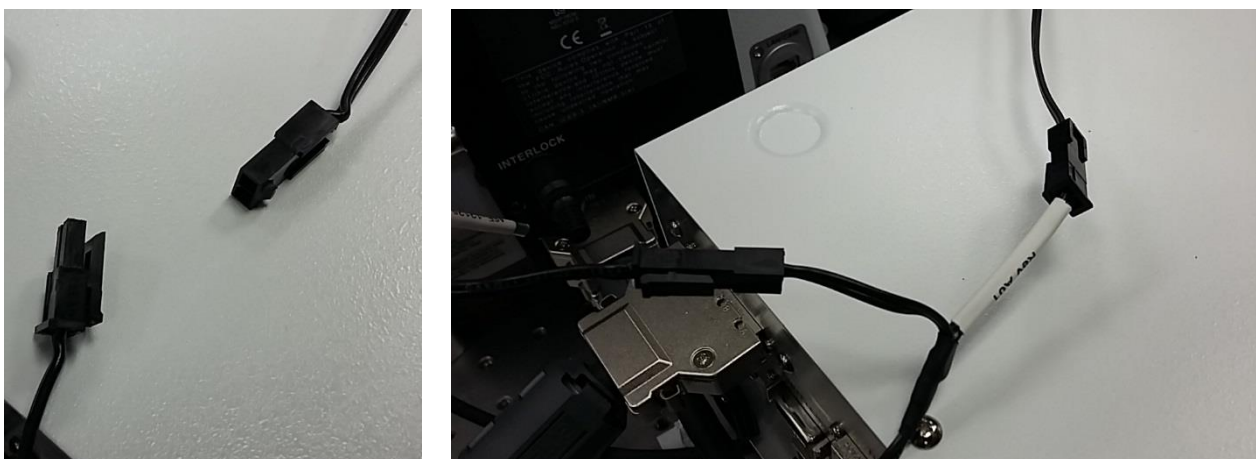

Figure 5: External Interlock Cable (ASE-11399) Connected into Interlock Cable Loom

9. Test the interlock system using the 'Guidelines for Safe Operation of Laser Products' in your *Hardware Guide*